

**DOCUMENT FEEDER**  
**(Machine Code: B696)**

# 1. REPLACEMENT AND ADJUSTMENT

## 1.1 EXTERIOR COVER

1. Open the upper cover [A].
2. Front cover [B] (⚙ x 1)
3. Rear cover [C] (⚙ x 1)

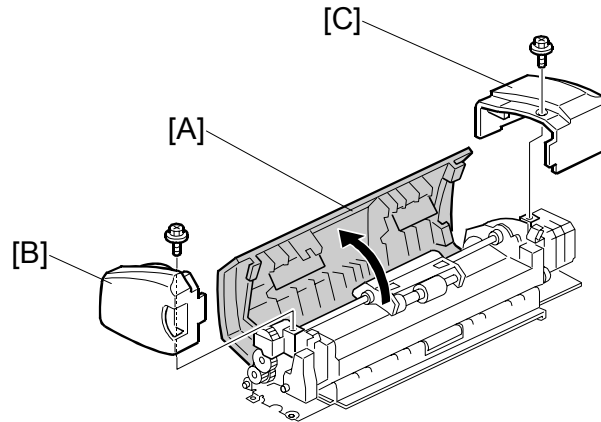

B696R907.WMFF

## 1.2 ORIGINAL TABLE

**CAUTION:** Do not damage the latches on the bottom.

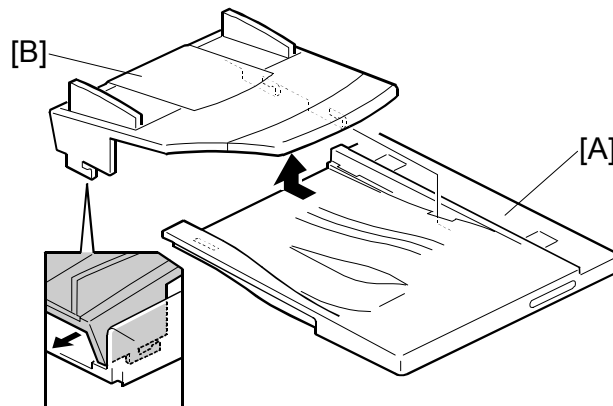

B696R901.WMF

1. Open the platen cover [A] (when the ADF main body is kept installed).
2. Slowly push the original table [B] to the left, and release the three latches on the bottom.

### *Reinstalling*

Use caution not to damage the three latches on the bottom. Make sure that the contact area around each latch is flush against the cover (➡ 1.5.2).

## 1.3 ROLLER

### 1.3.1 PICKUP ROLLER

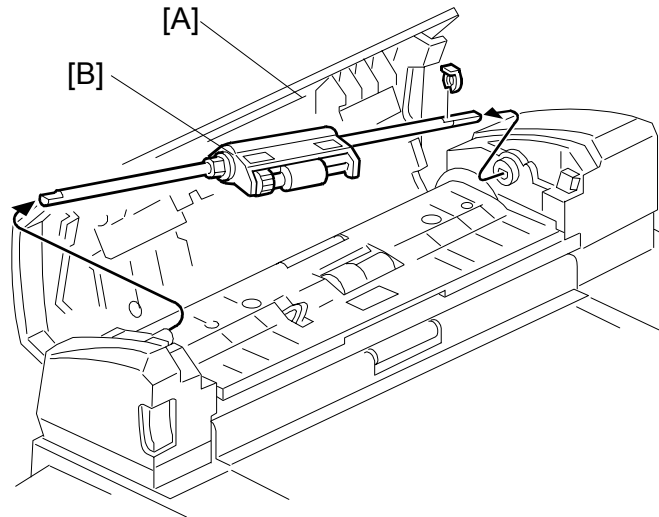

B696R908.WMF

1. Open the upper cover [A].
2. Feed unit [B] (☞ x 1)

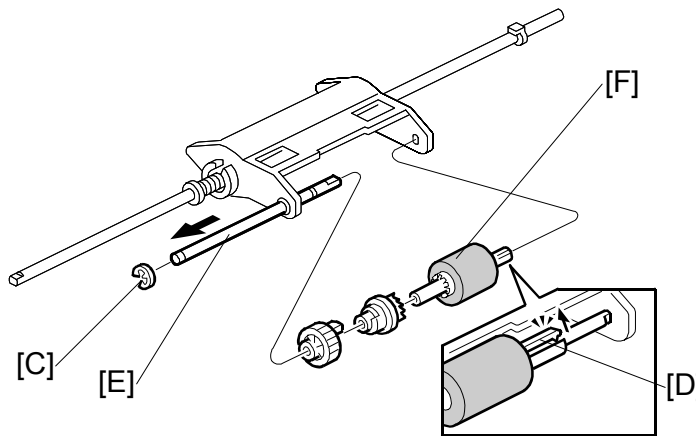

B696R909.WMF

3. E-ring [C]
4. Release the hook [D].
5. Shaft [E]
6. Pickup roller [F]

### 1.3.2 FEED ROLLER

1. Feed unit (☛ 1.3.1)
2. E-ring [A]
3. While pushing the shaft [B] to the left, slowly turn the shaft. The pin [C] comes off the opening of the holder [D].
4. Release the hook [E], and pull the shaft to the left.
5. Feed roller [F]

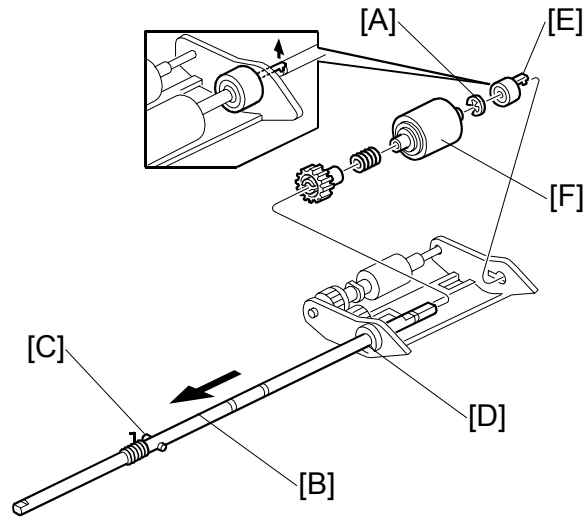

B696R910.WMF

### 1.3.3 SEPARATION ROLLER

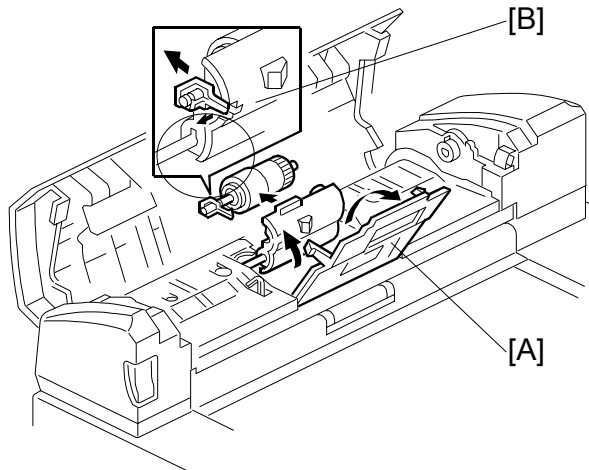

B696R912.WMF

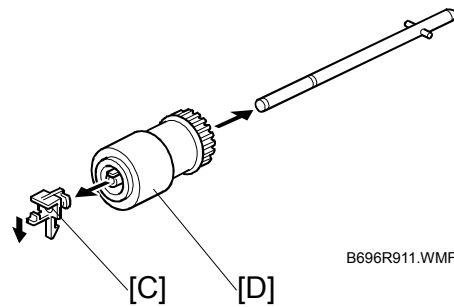

B696R911.WMF

1. Feed unit (☛ 1.3.1)
2. Open the center lid [A].
3. Separation roller assembly [B] (1 hook)
4. Hook [C]
5. Separation roller [D]

Peripherals

## 1.4 ADF MOTOR

1. Rear cover (☛ 1.1)
2. Push the lever [A] and raise the ADF [B].

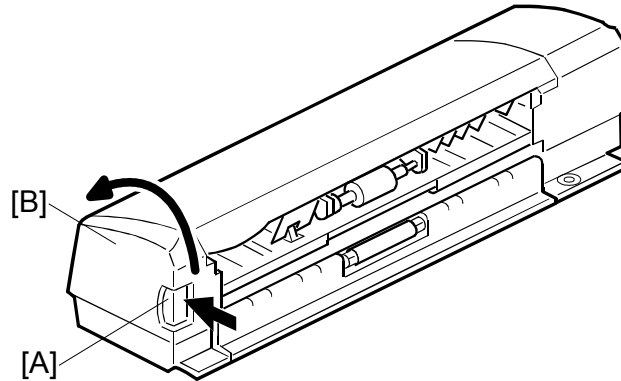

3. Motor cover [C] (☛ x 1)
4. Ground cable [D] (☛ x 1)
5. Unit open switch [E]
6. ADF motor (with the bracket) [F] (☛ x 1, ☛ x 2)

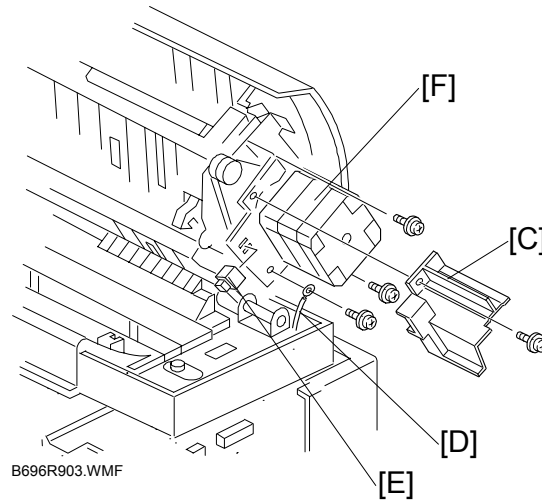

7. Gears [G][H]
8. Motor bracket [I] (☛ x 2)

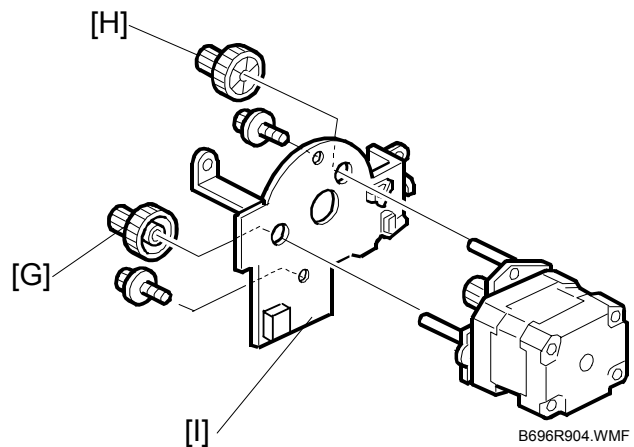

9. ADF motor [A] (⌀ x 2)

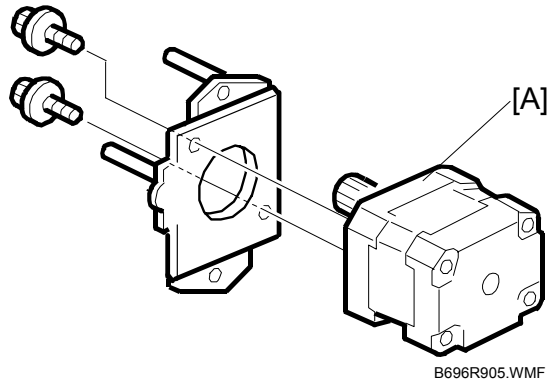

**Reassembling**

Check that the timing belt [A] is on the drive gear [B].

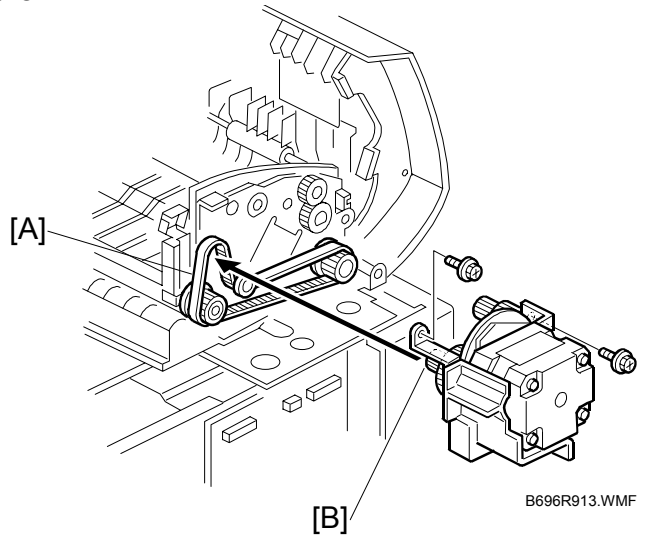

## 1.5 FEED CLUTCH

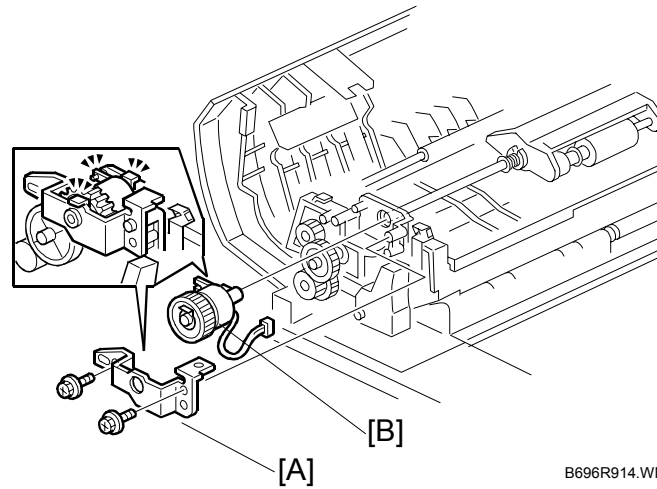

B696R914.WMF

1. Front cover (☛ 1.1)
2. Retainer [A] (🔩 × 2)
3. Feed clutch [B] (🔩 × 1)

## 1.6 SENSOR

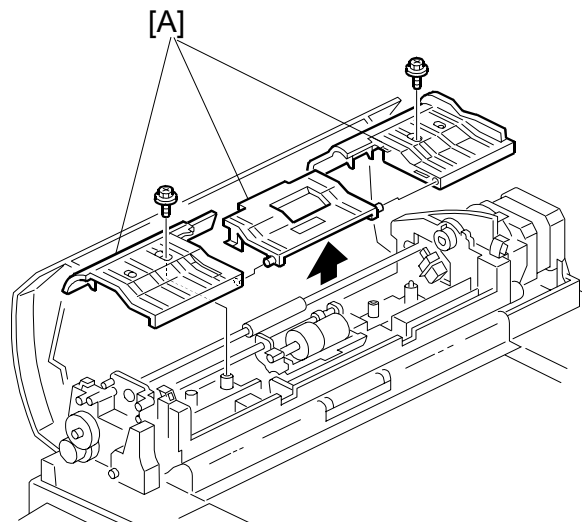

B696R915.WMF

1. Feed unit (☛ 1.3.1)
2. Three lids [A] (🔩 × 2)

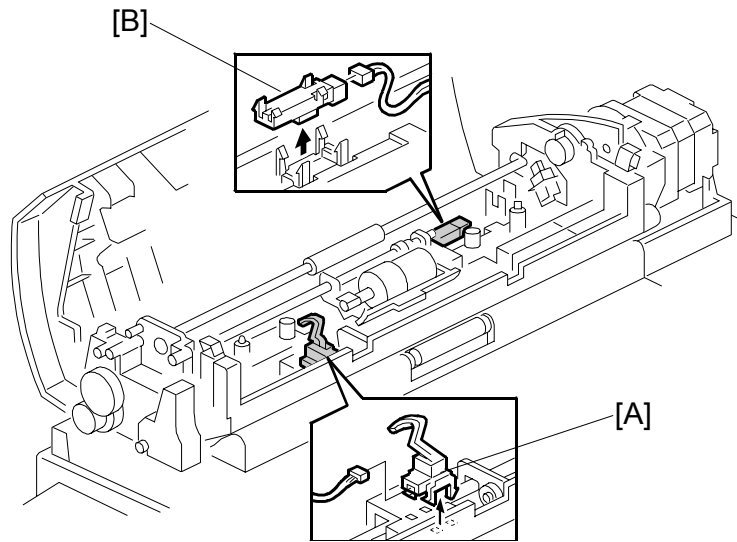

B696R916.WMF

- 3. Original set sensor [A] (☞ × 1)
- 4. Original registration sensor [B] (☞ × 1)

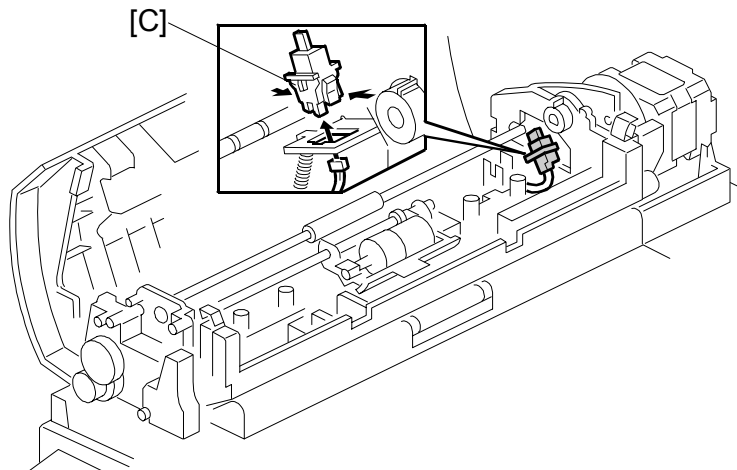

B696R917.WMF

- 5. Guide open sensor [C] (☞ × 1)



## 1.7 ADF EXPOSURE GLASS

1. Push the lever and raise the ADF (☛ 1.4).
2. Original exit guide [A] (☛ × 3)
3. ADF exposure glass [B]

### *Reassembling*

The pads on both ends indicate the upper side. Place the ADF exposure glass so that you see these pads on the top of the ADF exposure glass.

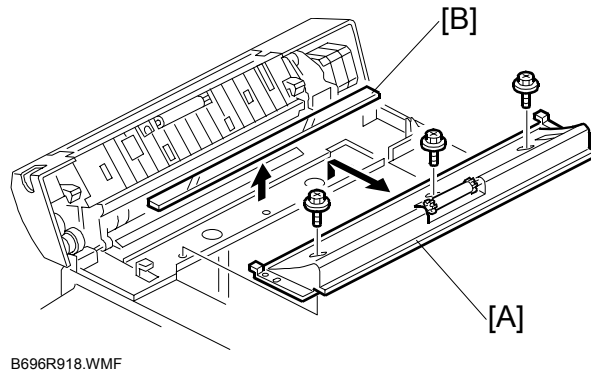

## 1.8 ADF CONNECTION BOARD

1. Memory card cover [A] (☛ × 1)
2. Rear cover of the copier [B] (☛ × 5)

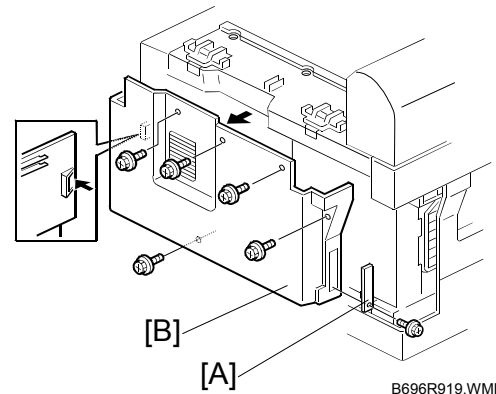

3. ADF connection board guard [C] (☛ × 2)
4. ADF connection board [D] (All ☛'s, ☛ × 2)

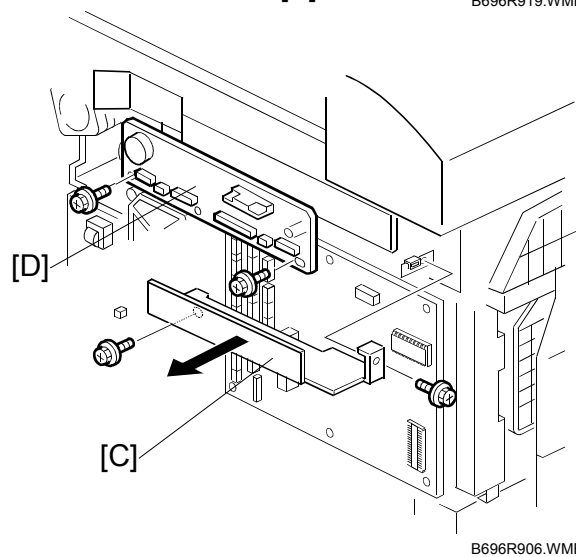

---

## 2. DETAILED DESCRIPTIONS

### 2.1 OVERVIEW

#### 2.1.1 MECHANICAL COMPONENT

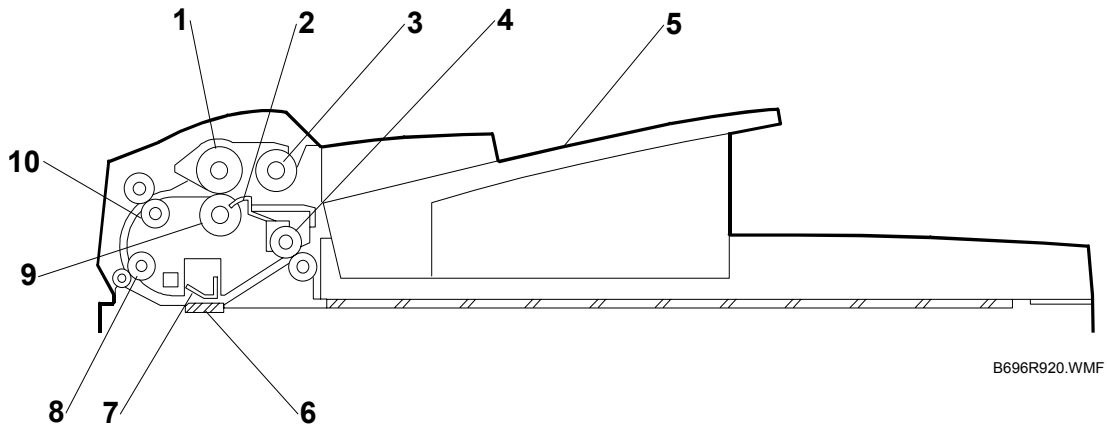

- |                                      |                          |
|--------------------------------------|--------------------------|
| 1. Feed roller                       | 6. ADF exposure glass    |
| 2. Feeler of the original set sensor | 7. White plate           |
| 3. Pickup roller                     | 8. 2nd transport roller  |
| 4. Original exit roller              | 9. Separation roller     |
| 5. Original table                    | 10. 1st transport roller |

## 2.1.2 ELECTRICAL COMPONENT

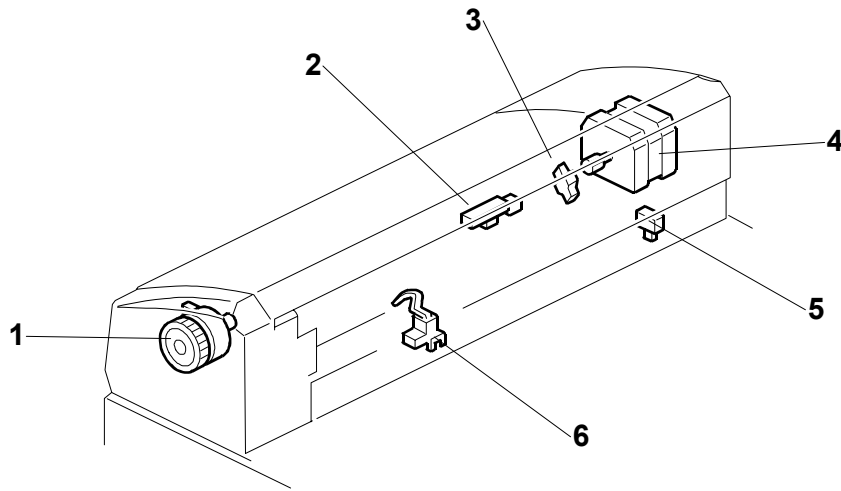

B696R921.WMF

- |                                 |                        |
|---------------------------------|------------------------|
| 1. Feed clutch                  | 4. ADF motor           |
| 2. Original registration sensor | 5. Unit open switch    |
| 3. Guide open sensor            | 6. Original set sensor |

### 2.1.3 DRIVE LAYOUT

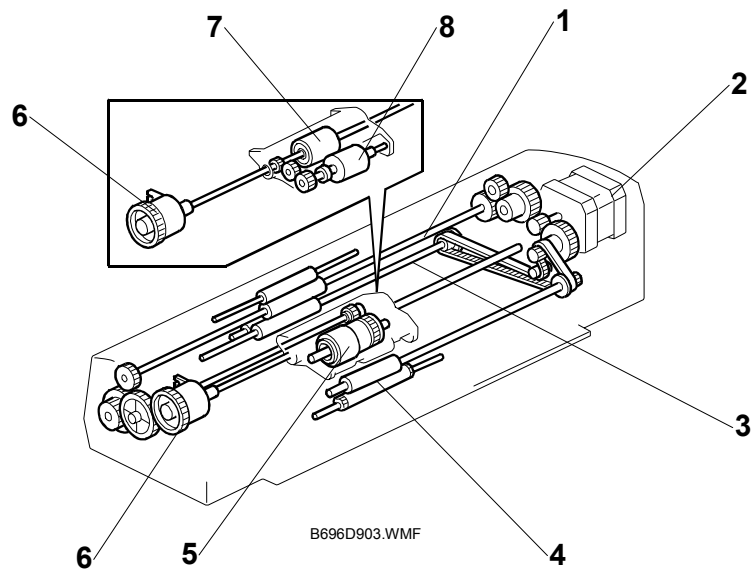

- |                         |                      |
|-------------------------|----------------------|
| 1. 1st transport roller | 5. Separation roller |
| 2. ADF motor            | 6. Feed clutch       |
| 3. 2nd transport roller | 7. Feed roller       |
| 4. Exit roller          | 8. Pickup roller     |

## 2.2 CIRCUIT CONNECTION

The table lists the connectors that link each component to the BICU. The connectors CN303 through CN307 link each component to the ADF connection board. The connectors CN302 and CN301 link the ADF connection board to the BICU.

Component	ADF Connection board		BICU
	ADF	Connection board	
ADF motor	CN303	CN302	CN109
Original set sensor	CN305	CN301	CN110
Original registration sensor			
Guide open sensor			
ADF clutch	CN306		
Unit open switch	CN307		

## 2.3 ORIGINAL DETECTION

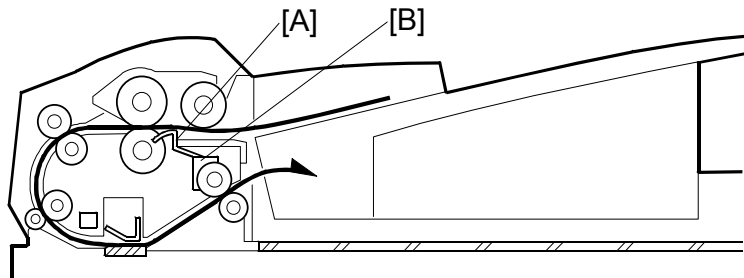

B696D900.VWMF

When you set an original on the original table, the original pushes down the feeler [A] of the original set sensor [B]. The copier recovers from its energy saver mode if it is in the mode.

**NOTE:** The ADF does not scan the reverse side of the original. The ADF does not detect paper sizes.

## 2.4 PAPER TRANSPORT

### 2.4.1 PICK-UP AND FEED

The ADF motor [D] drives the feed clutch [F]. The clutch transmits the drive power to the feed-roller shaft [A] when it is on, and does not transmit the drive power when it is off. The pick-up roller [C] stays away from the original when not transporting the original. When you press the start key, the ADF motor starts turning clockwise (viewed from the machine front). The feed clutch turns on. The feed-roller shaft starts to turn clockwise. As linked to the feed-roller shaft, the pick-up roller comes down to the original, and picks up the original. The feed roller [B] transports the original to the 1st transport roller [G].

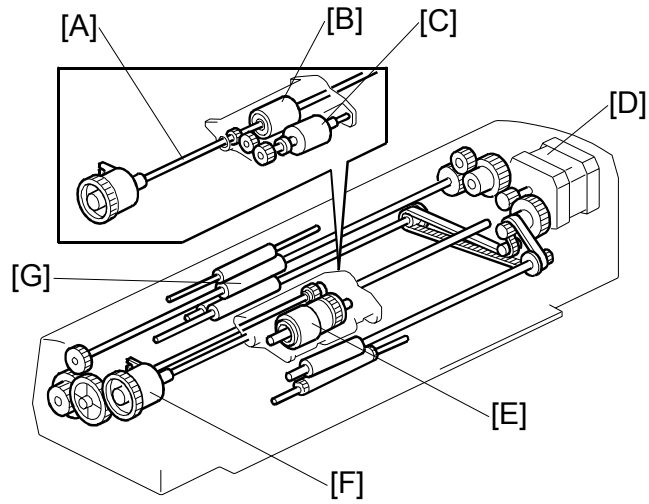

B696D901.WMF

### 2.4.2 SEPARATION

The ADF motor drives the separation roller [E]. The separation roller turns counterclockwise while the ADF motor operates.

### 2.4.3 REGISTRATION

The following rollers transport originals to the original registration sensor:

1. Pick-up roller
2. Feed roller
3. 1st transport roller
4. 2nd transport roller

When an original reaches the original registration sensor, the ADF motor stops operation and the feed clutch turns off. No roller turns until the scanner becomes ready. When the scanner becomes ready, the ADF motor starts turning; the 1st and 2nd transport rollers (and separation roller) start to turn to transport the original. On the other hand, the feed clutch does not turn on; the drive power is not transmitted to the pick-up and feed rollers.

**NOTE:** Though the drive power is not transmitted to the pick-up and feed rollers, you see these rollers turning. They are moving with the originals as they are transported.

## 2.5 CORRECTION

### 2.5.1 WHITE LEVEL CORRECTION

While the ADF is operating, the scanner conducts the white level correction. When an original reaches the original registration sensor, the ADF motor stops briefly. The scanner checks the white peak every time the ADF transports an original.

### 2.5.2 SHADING CORRECTION

The scanner conducts the shading correction every 10 originals. The ADF motor stops and waits for the scanner to conduct shading correction.

## 2.6 UNIT OPEN SWITCH AND GUIDE OPEN SENSOR

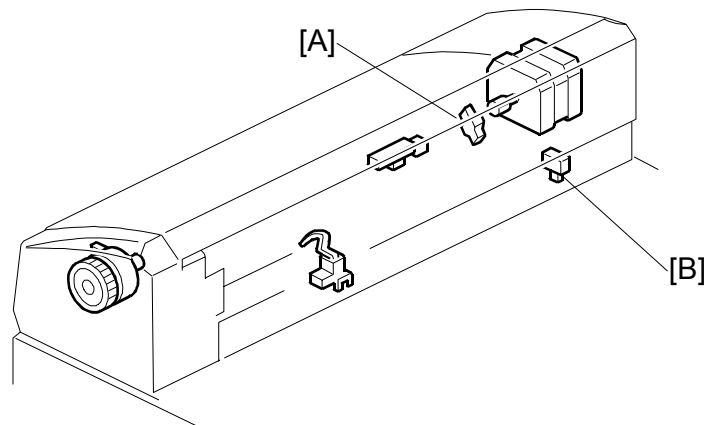

B696D902.WMF

The guide open sensor [A] is on while the ADF guide is open. The unit open switch [B] is on when the ADF unit is raised. The scanner does not operate when either of them is on, and display a message.